

LÍNEA LONG LIFE

Características.

- Soporte antivibratorio industrial.
- Goma compuesta NR 65° ± 5° Shore A.
- Birlo en acero galvanizado.
- Cuenta con barrenos para la fijación al piso.
- Funciona a compresión
- Capacidad de carga de 700Kg
- **Acero inoxidable sobre pedido.**



SKU	A	B	C	D	E	F	G	H	I	J	K
22983	4.11"	2.8"	2.12"	3/16"	3.20"	3.2"	2.8"	1/2"	35/64"	1.74	1.8"

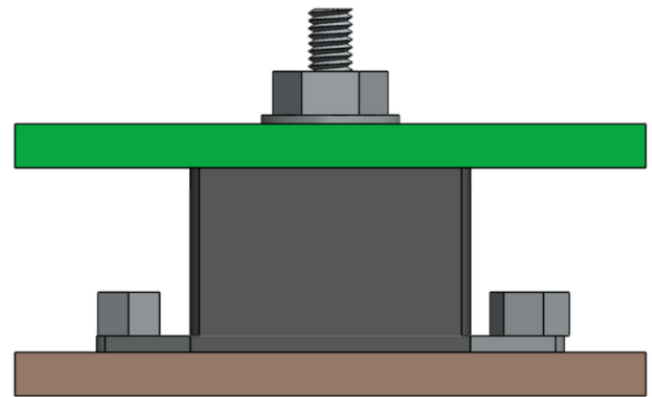
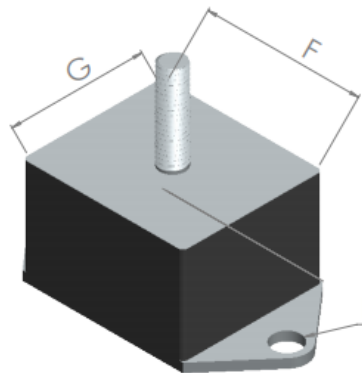
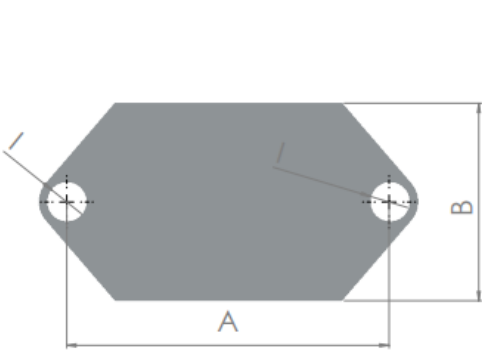

Colocación adecuada

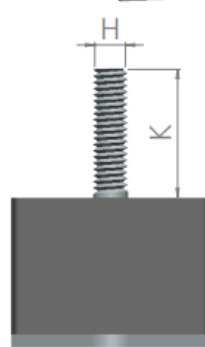
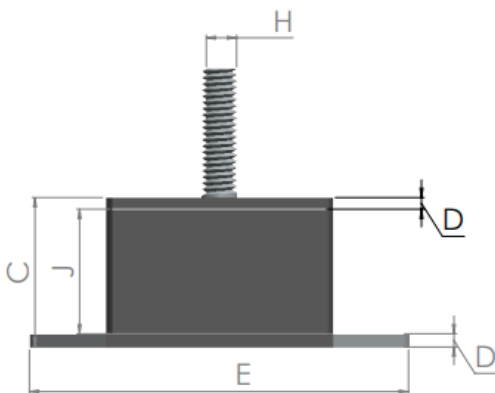

Vista 3D y cotizador en línea



<https://inahermex.com/>